

MODEL 2410 DUST COLLECTOR

SERIES CMC STEEL CONSTRUCTION PAINTED EXTERIOR

SERIES SSC STAINLESS STEEL EXTERIOR

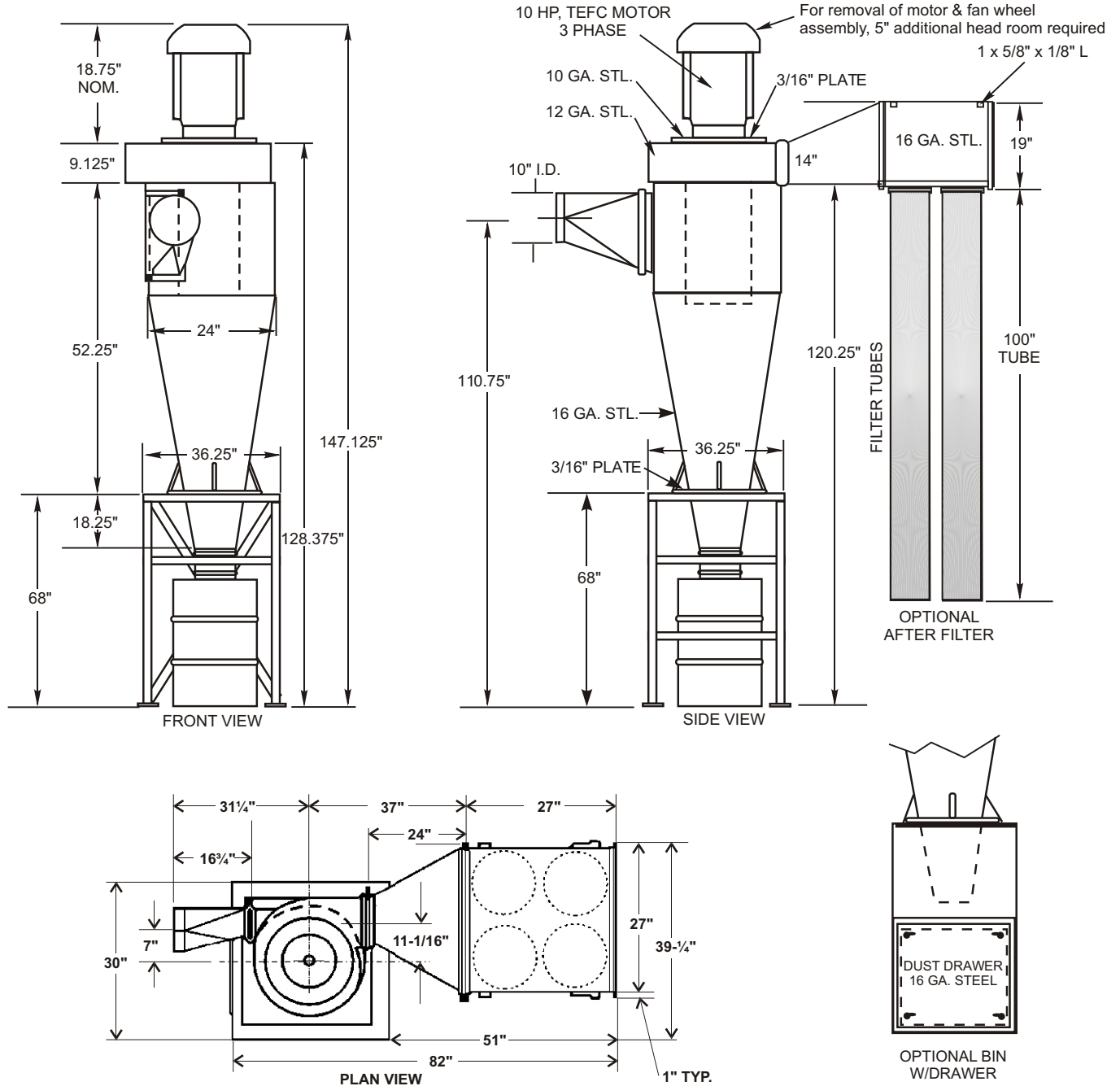

QTY.	SERIES	MODEL	VOLTAGE	PHASE	AFTER FILTER	AFTER FILTER ENC.	BIN W/DRAWER	Performance Table			
								CFM	FPM (VELOCITY)	STATIC PRESSURE	BHP
		2410						2000	3670	10.9"	7.4
		2410						2400	4400	9.4"	7.7
								2800	5130	7.6"	8.1
								3200	5870	5.7"	8.5
								3600	6600	3.8"	8.8

SPECIFICATION
 Collector will be of the high velocity cyclone type and fabricated of heavy gauge steel and complete with direct connected totally enclosed motor and 55 gallon drum collector. The fan wheel shall be radial blade type with flat blades and constructed of 10 gauge steel, mounted directly on the fan motor shaft, and shall be essentially self-cleaning. Cyclone body shall be all welded construction, and shall be adequately stiffened internally so as to properly support the cyclone. Base shall be constructed to adequately support collector and contain a 55 gallon drum for the dust collection. Optional after filter shall consist of one plenum module with assembly that includes steel transition between fan discharge and plenum holding four bags. The filter bags are of flame retardant cotton sateen fabric, tubular design with zippered bottoms. An optional steel constructed after filter enclosure is available.