

## CAR-MON SERIES RCO REFUSE CLEAN-OUT PLENUM

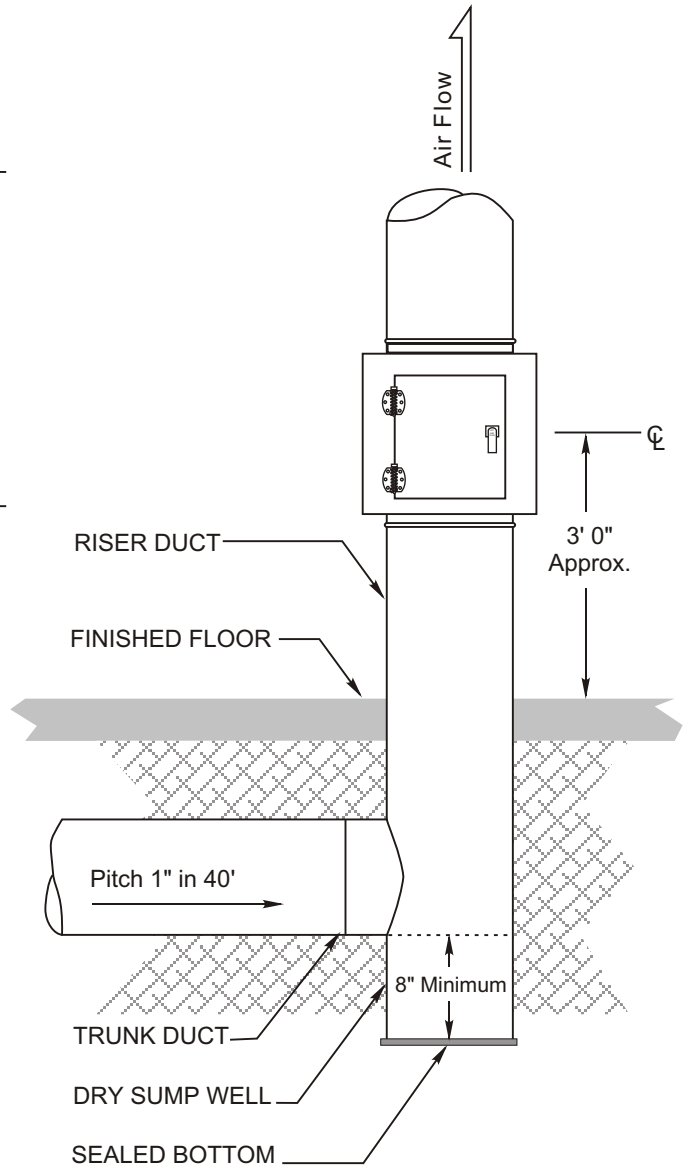
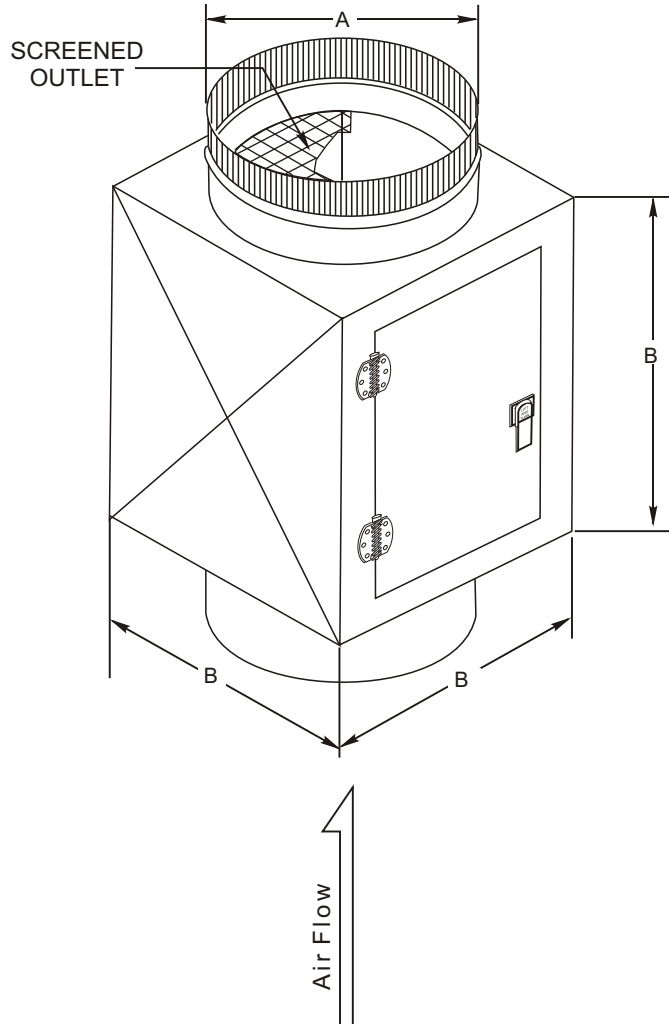

QTY.	MODEL	A	B
	RCO-10	10"	14"
	RCO-12	12"	14"
	RCO-14	14"	16"
	RCO-16	16"	18"
	RCO-18	18"	22"

**Series RCO** refuse clean-out plenums are designed as a debris trap to protect the exhaust fan while providing access to the underground ducting system through the riser duct for removal of accumulated refuse and insertion of a sump pump to eject water should the system become flooded.

The refuse clean-out shall be constructed of minimum 20 gauge galvanized steel with positive close, gasketed access door with heavy duty, cad plated, spring loaded leaf spring, and adjustable draw latch. A screen mesh of 1/2" x 1/2" shall be provided across the outlet opening.

**Note:** Factory reserves the right to change dimensional data without notice.