

DIMENSIONS ARE IN INCHES

CMX-24-D FILTER UNIT

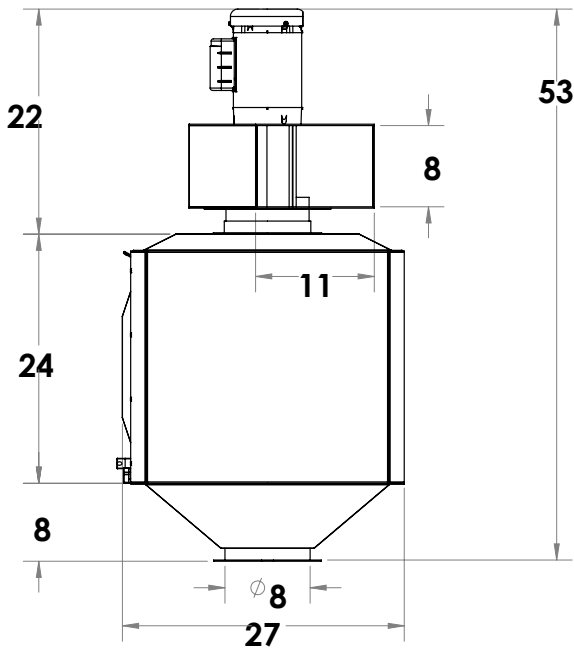

SIDE VIEW

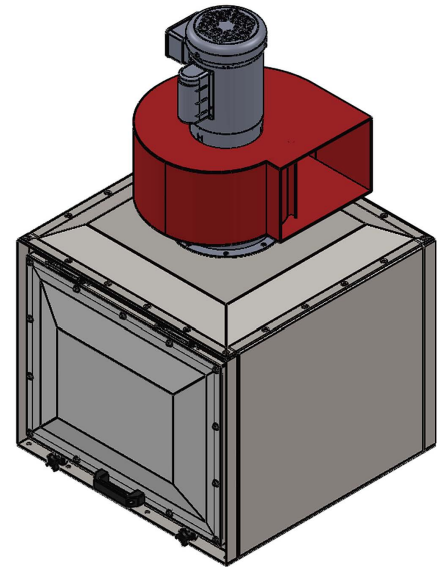
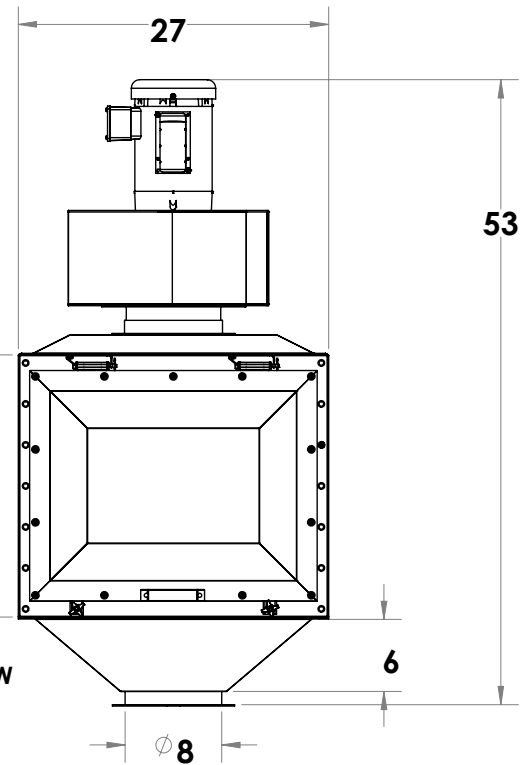

FRONT VIEW

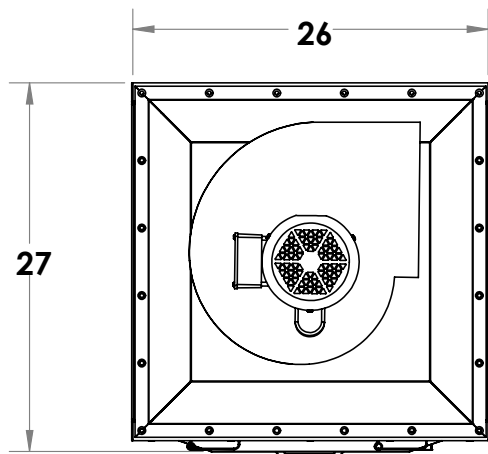

TOP VIEW

QTY.	MODEL	HP	CFM	VOLT/PH/Hz	ALUMINUM PRE-FILTER	PRE-FILTER	FILTER TYPE			OPTIONS
							95% MEDIA	HEPA	CARBON	
	CMX-24									FILTER GAUGE

Model CMX filter unit is designed to clean contaminated air and fine nuisance dust. It shall be provided as a self-contained package with a filter and exhaust fan with hanging support lugs. The contaminated air will travel through the inlet side of the cabinet and into a three stage filtering process. The first stage aluminum pre-filter shall protect against sparks and hot embers, the second stage shall be a be MERV 8 high capacity fabric filter and a final stage MERV 15 final filter.

For filter access, cabinet shall have a removable hinged door with turn knobs for a no tool quick filter change-out. The filter box is constructed of high strength steel with a polyurethane powder coat finish. Unit shall ship assembled with easy on-site installation. Unit supplied with inlet and outlet flanged plenum's for quick bolt up connection to ducting and exhaust fan transitions.

Other sizes and custom configurations available, please consult factory. Series CMX is manufactured by Car-Mon Products, Inc. of Elgin, Illinois.