

# MODEL 3015 DUST COLLECTOR

## SERIES CMC STEEL CONSTRUCTION PAINTED EXTERIOR

## SERIES SSC STAINLESS STEEL EXTERIOR

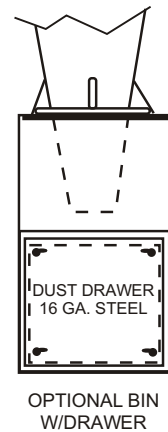
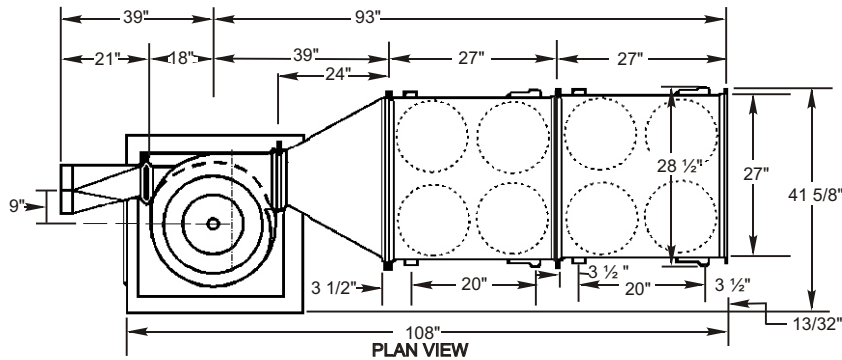
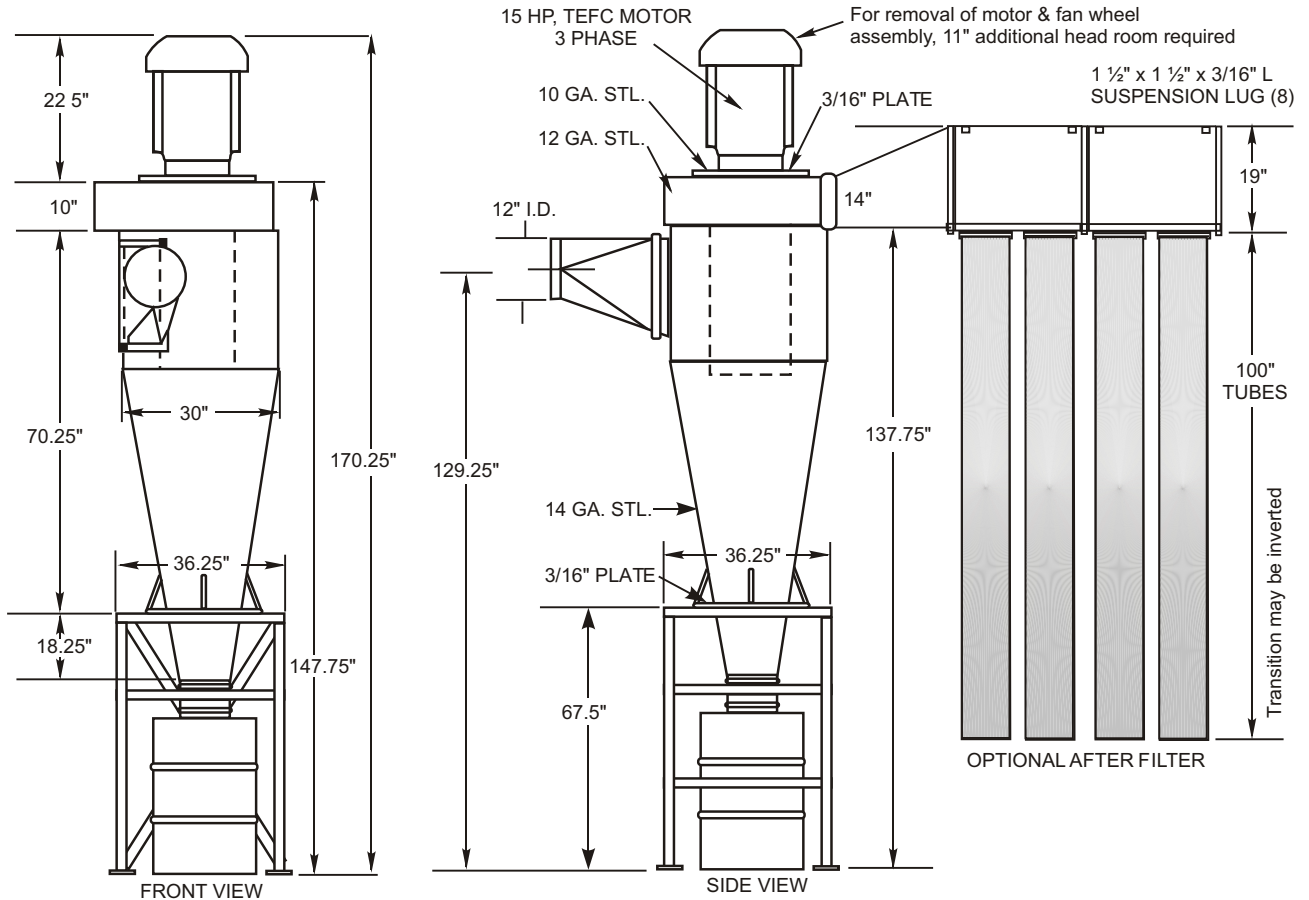

QTY.	SERIES	MODEL	VOLTAGE	PHASE	AFTER FILTER	AFTER FILTER ENC.	BIN W/DRAWER	Performance Table			
								CFM	FPM (VELOCITY)	STATIC PRESSURE	BHP
		3015						2500	3180	14.1	11.3
		3015						3000	3820	12.4	11.9
<b>SPECIFICATION</b> Collector will be of the high velocity cyclone type and fabricated of heavy gauge steel and complete with direct connected totally enclosed motor and 55 gallon drum collector. The fan wheel shall be radial blade type with flat blades and constructed of 10 gauge steel, mounted directly on the fan motor shaft, and shall be essentially self-cleaning. Cyclone body shall be all welded construction, and shall be adequately stiffened internally so as to properly support the cyclone. Base shall be constructed to adequately support collector and contain a 55 gallon drum for the dust collection. Optional after filter shall consist of two plenum modules with assembly that includes steel transition between fan discharge and plenum with each plenum holding four bags each. The filter bags are of flame retardant cotton sateen fabric, tubular design with zippered bottoms. An optional steel constructed after filter enclosure is available.								3500	4460	10.5	12.5
								4000	5090	8.5	13.1
								4500	5730	6.4	13.6
								5000	6370	4.3	14.1