

DYNAMOMETER PACKAGE

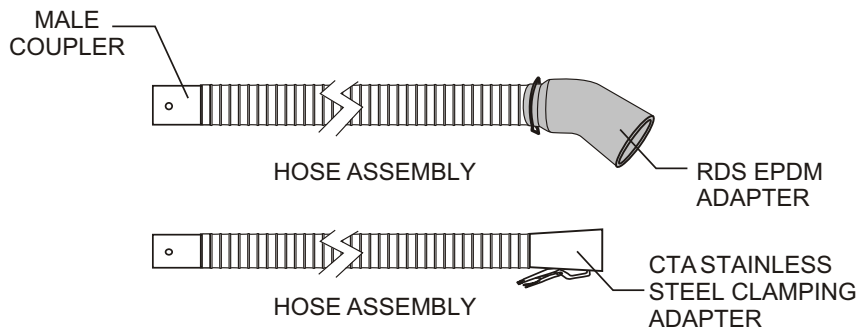

CAR-MON DOWN DROPS SERIES SDA & DDA

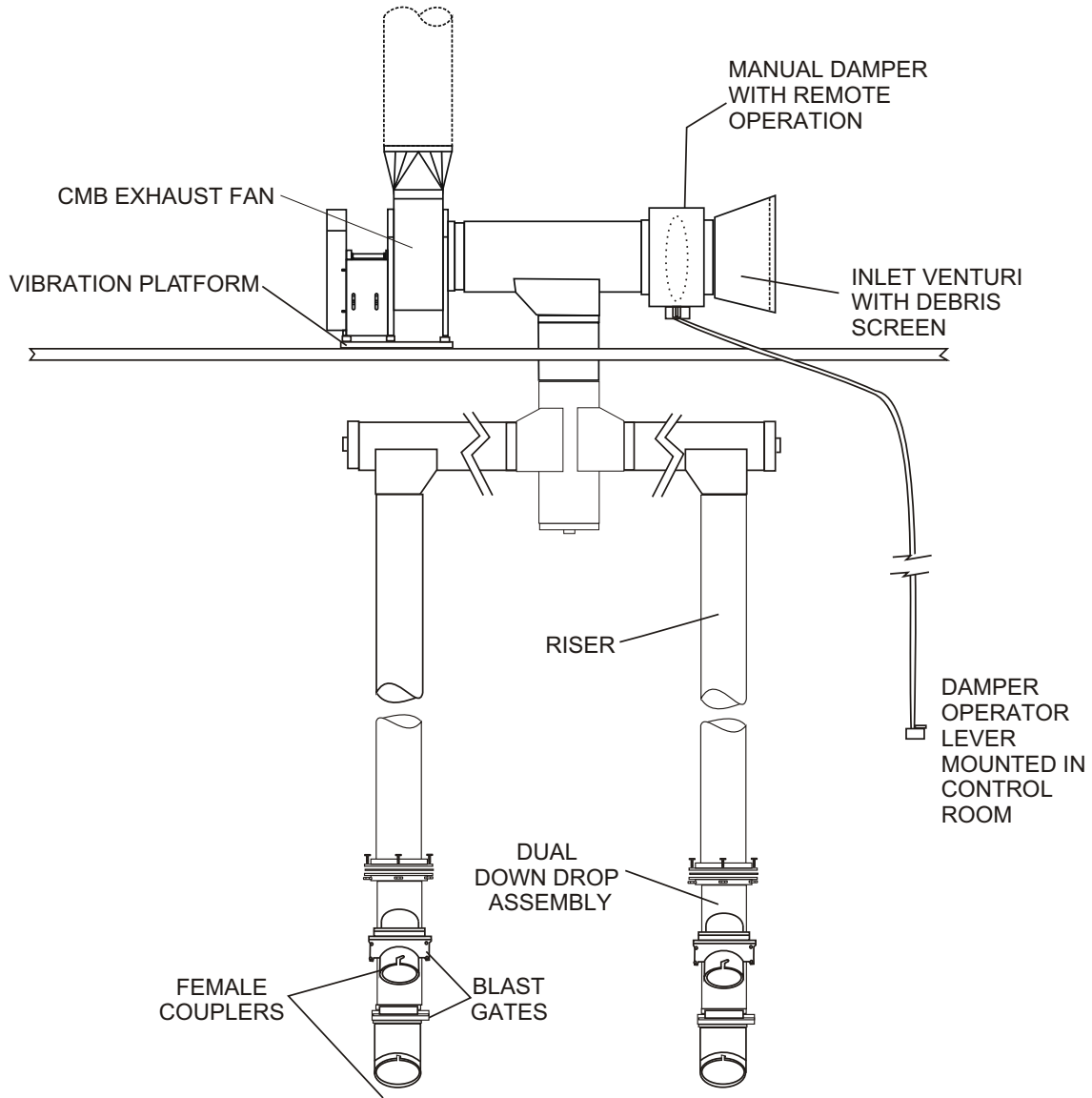
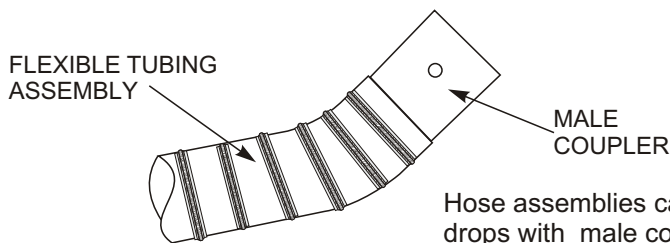
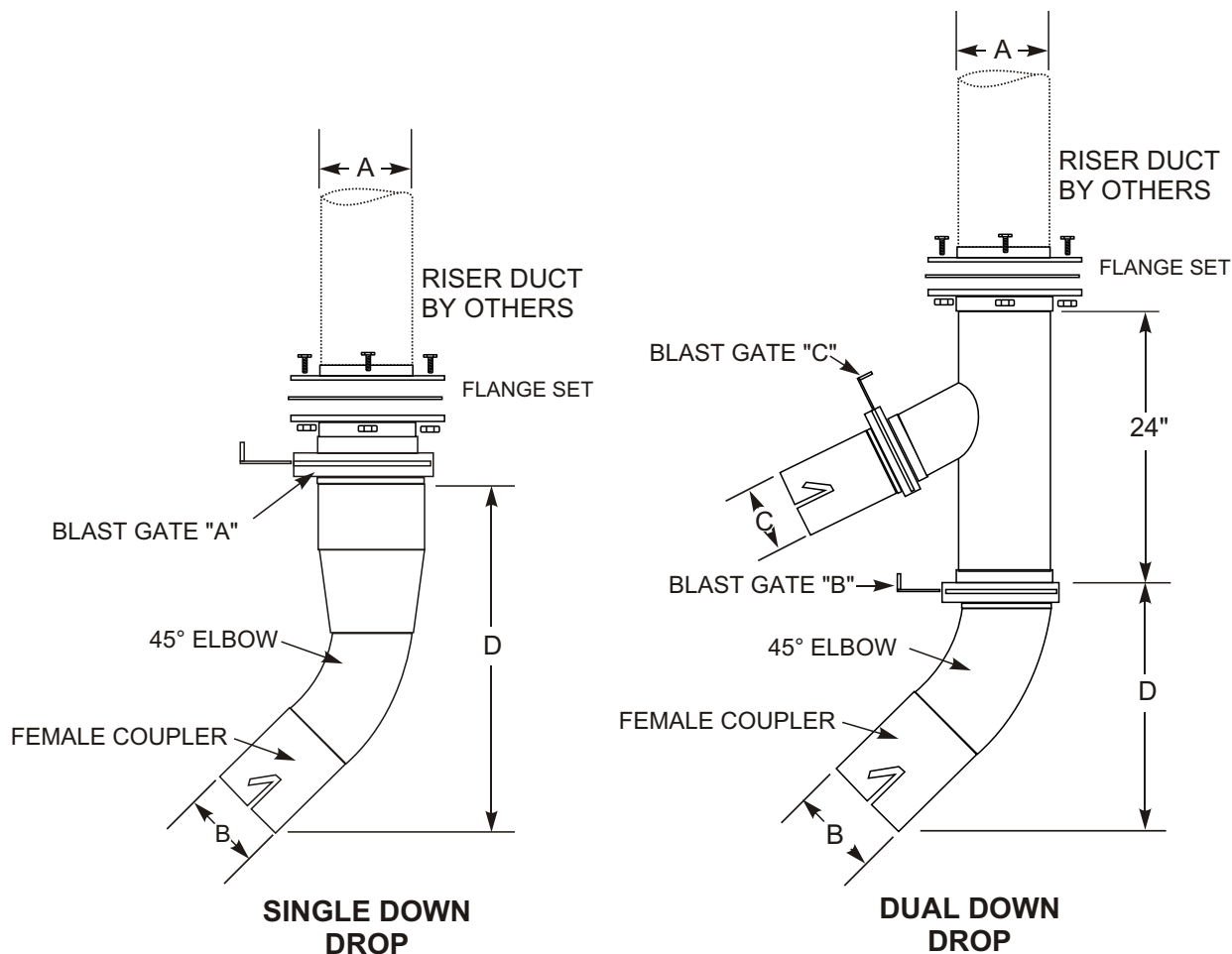

SINGLE DOWN DROP					DUAL DOWN DROP					Car-Mon DOWN DROP fittings are constructed of 20 gauge galvanized sheet metal, with Series CM female couplers and Series BG blast gate dampers. An angle ring flange is welded to the duct connection end; a matching flange gasket and hardware is provided with the assembly. Connection to the down drop can be made easily with a hose assembly having a Series CM male coupler. For special diameters or other configurations, contact the factory.
QTY.	MODEL NUMBER	"A" DIA.	"B" DIA.	"D"	QTY.	MODEL NUMBER	"A" DIA.	"B" DIA.	"C" DIA.	
	SDA-4		4"			DDA-43		4"	3"	
	SDA-5		5"			DDA-54		5"	4"	
	SDA-6		6"		→	DDA-64	8"	6"	4"	
	SDA-7		7"			DDA-66		6"	6"	
	SDA-8		8"			DDA-86		8"	6"	

CAR-MON DYNO STAND (OPTION)

