

WALL MOUNTED BRAKE WINCH

MOUNTING HOLES IN EACH CORNER OF WALL BRACKET

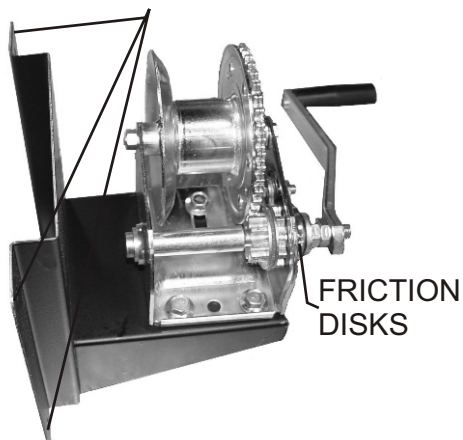

OVERVIEW AND PRECAUTIONS FOR USING BRAKE WINCH

1. Read, understand and follow all instructions before installing and/or using product. NEVER allow anyone unfamiliar with the operating instructions to use this product.
2. The manufacturer or Car-Mon cannot be held liable for improper installation, use, or maintenance of this product.
3. Do not get oil or grease on the friction disks, This could allow the load to slip or fall.
4. Do not let anyone be positioned under or around the load being lifted.
5. Always inspect the cable. NEVER use with a frayed cable.
6. A loud clicking sound from the ratchet must be heard when lifting the load. If a loud clicking sound is not heard, do not use and replace ratchet components immediately. When lowering the load, no clicking will be heard because the braking system is activated.
7. Failure to operate the winch in a safe manor could result in serious bodily harm and/or damage to the equipment.

MOUNTING INSTRUCTIONS

1. Assemble handle onto input shaft end. Tighten the 1/2-13 locknut against handle. Note: Do not remove or adjust the double locknuts on long end of input shaft. They are an important part of the braking system and must be intact.
2. Mount the winch securely to a wall or beam capable of supporting at least 5 times the load the winch will be pulling.

CABLE ATTACHMENT TO DRUM

1. Always be sure the cable is pulling straight off the winch, not at an angle. This will prevent the cable from rubbing against the sides of the drum, which can damage the cable. When tube is in full down position, there must be a MINIMUM of three winds of cable on the drum at all times. There is 100' of cable supplied. Excess cable MUST be cut off. There should be no more than 3 wraps of cable on the drum when the hose is fully extended.
2. Run cable through side of drum hole as shown at right. Push cable through the aluminum sleeve and crimp tightly so that it cannot be pulled out.

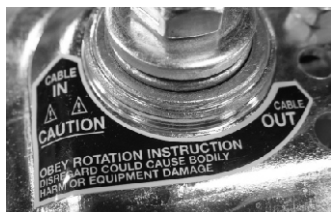
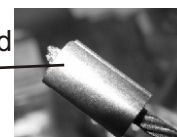
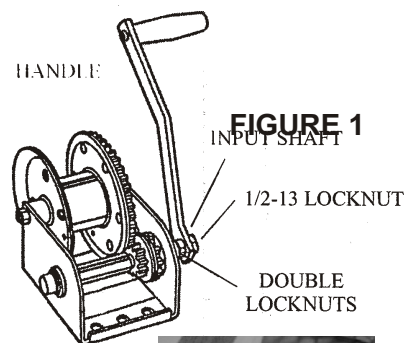

Cable In/Cable Out decal

OPERATING INSTRUCTIONS

1. Turning the handle counter-clockwise actuates the brake. The brake system is designed to hold the load whenever the handle is released.

TO PULL CABLE IN OR RAISE LOAD

1. The cable must be securely fastened to the object being lifted and to the winch drum.
2. Always be sure that the cable and cable attachments are not damaged and are strong enough for the load. Assure there is adequate safety factor, of at least three times the maximum load for all components used.
3. Referring to the "Cable In/Cable Out" decal (see above) on the winch, turn the handle clockwise to lift. The ratchet **MUST** make a loud clicking sound when lifting load..

TO LET CABLE OUT OR LOWER LOAD

1. Referring to the "Cable In/Cable Out" decal on the winch, turn the handle counter-clockwise to lower. No clicking will be heard because the brake system is activated.

MAINTENANCE

1. Maintain a film of lithium grease on all gear teeth and to the O.D. of drum bearing at all times. Keep ratchet paw pivot, bushings and pinion threads lubricated with automotive engine oil at all times.
2. Keep friction disks free of grease or oil.
3. Check brake friction disks for wear. If less than 1/16" thick, cracked, or broken, they must be replaced.
4. During each usage, check for proper ratchet operation. When cranking cable in, a loud clicking sound must be heard from the ratchet. If a loud clicking sound is not heard, do not use and replace damaged components immediately. When cranking cable out, there is no clicking and the ratchet pawl must be fully engaged into the ratchet gear teeth.

OPERATION PRECAUTIONS

1. Before lowering hose or the load, always make sure the area below is clear. Always lower hose to full length position, do not operate the system with the hose partially retracted. **NEVER** operate the winch when other people are near the area where the hose is being lowered or retracted.
2. **NEVER** attach or detach the exhaust adapter to a vehicle that is running. After servicing, let the fan run a few minutes after the vehicle is shut off to cool down the adapter and hose.
3. Before retracting the hose or load, make sure hose is not tangled or obstructed.
4. Follow maintenance instructions for the brake winch. Periodically check the aircraft cable to make sure it is not frayed.