

## CAR-MON DUST COLLECTORS SERIES 207, 2410, 3015

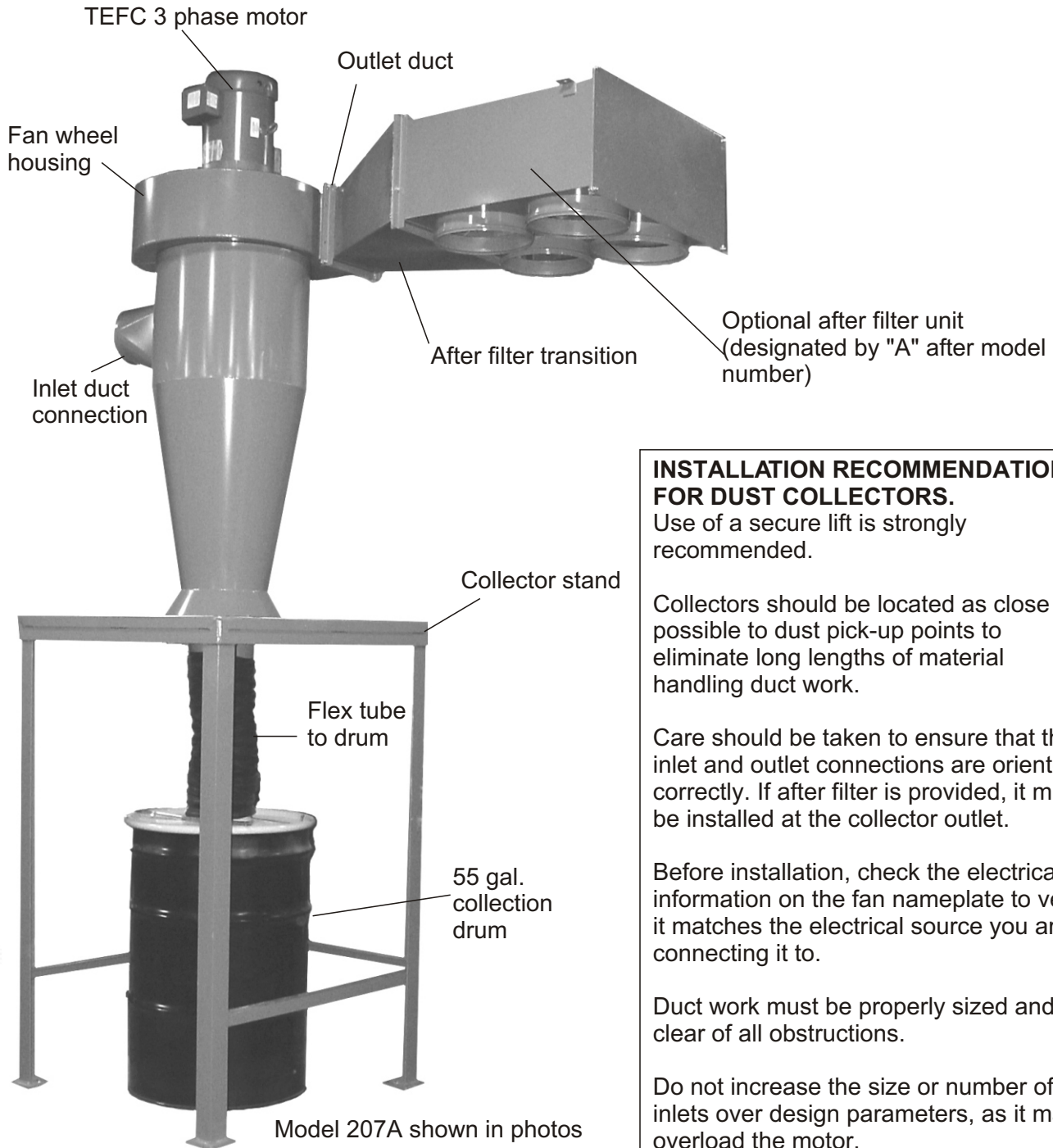

### INSTALLATION RECOMMENDATIONS FOR DUST COLLECTORS.

Use of a secure lift is strongly recommended.

Collectors should be located as close as possible to dust pick-up points to eliminate long lengths of material handling duct work.

Care should be taken to ensure that the inlet and outlet connections are oriented correctly. If after filter is provided, it must be installed at the collector outlet.

Before installation, check the electrical information on the fan nameplate to verify it matches the electrical source you are connecting it to.

Duct work must be properly sized and clear of all obstructions.

Do not increase the size or number of inlets over design parameters, as it may overload the motor.

# INSTALLATION



Note: Instructions are shown with an optional after filter. If an after filter is not used, the outlet will be attached to duct work rather than the after filter.

1. Unpack all components, making sure all pieces are accounted for.
2. Prepare surface for mounting of collector platform. Bolt securely to floor or other supporting surface. Collectors can weigh up to 1500 lbs. Make sure platform is **level**.
3. Mount cyclone portion of collector on platform, making sure inlet and outlet is in correct orientation. Secure with bolts provided from underside of platform.

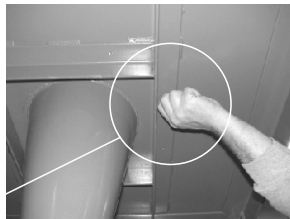

Secure cyclone on platform with bolts, from underside of platform.

**Step 3:** Mount cyclone portion on collector platform.

**NOTE: Caulk all mating components with commercial grade silicone prior to assembly to insure that connection is air-tight.**

4. Attach motor and fan housing. (Note: This piece is very heavy) This can be performed in 2 ways. Option 1: You can first detach the motor and fan from the top of the housing and have better access to attach housing, or reach inside the outlet and align holes and then bolt complete housing to cyclone. **Make sure all bolts at bottom of housing as well as those holding motor and fan at top of housing are tight!**



**Step 4**



**Step 4**

Option 2: You can also attach the housing while it is still connected to the fan and motor by aligning the bolt holes of the housing with the bolt holes of the cyclone. As holes are aligned, start the bolts, but do not tighten until all the bolts have been started. After tightening bolts, make sure the bolts holding the motor and fan wheel to the top of the housing are also tight and secure.

5. After attachment of fan housing, make sure all bolts on unit are tight and unit is completely secure. Wire motor using wiring diagram at end of manual. Unit should be tested to make sure fan is operating properly and that fan wheel is rotating in the proper direction by comparing wheel rotation with the rotation arrow on the fan housing. Use extreme caution when testing. Do not get close to inlet or outlet when fan is running!
6. If optional after filter is not on the system, duct work may be attached at this time. If after filter is being used, go to step 7.

**NOTE: STEPS 7 & 8 FOR UNITS WITH AFTER FILTER ONLY**

7. Attach after filter plenum to exhaust flange. The plenum has a flat bottom and an angled top. Make sure the angle is on the top for proper air flow.



**Step 7**



**Step 7**



**Step 8**

8. After securing plenum to collector unit, attach outside plenum cover. Before initial use of unit, attach cloth collection bags to each of the outlets, making sure they are secure.

9. Attach inlet duct connection to unit, securing with bolts provided.



**Step 9**



**Step 10**

10. Loosen band connection on collection drum. Remove cover (units are usually shipped with cover in inverted position) and turn drum cover. Tighten clamp so drum is sealed.

11. Install collector drum tube between the bottom of the collector and the top of the drum. Make sure tube is snug on both ends.

12. Secure tubing top and bottom with band clamps provided.



**Step 11**



**Step 12**  
Secure both ends of tubing with band clamps provided.

13. Wire motor to collector. Responsibility of electrical work is that of the contractor, with installation according to local codes. Motor failure due to improper wiring is not covered by manufacturer's warranty. Warranty for motor is provided by the motor manufacturer only.

This diagram covers most standard ODP 3-phase Baldor motors (7½ HP thru 15HP) supplied on Car-Mon dust collectors. Check model numbers of motors below.  
 VM3709T (7.5HP)  
 VM3711T (10HP)  
 VM3713T (3713T)  
 Motors above are designed for 3 phase 230/460 volts, but may be used at 208 volts.

**WIRING DIAGRAM FOR THREE PHASE BALDOR MOTORS**

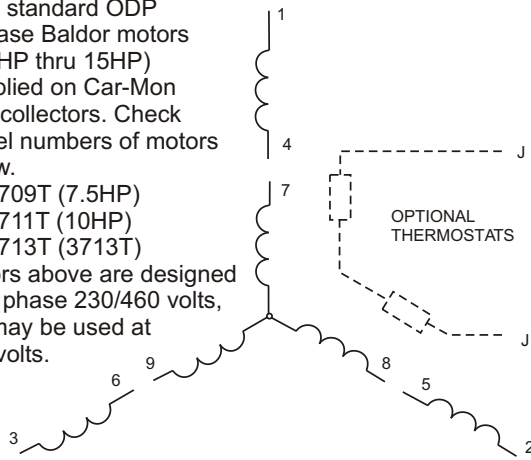
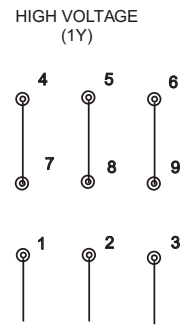
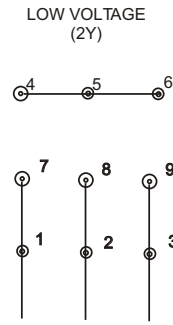

DIAGRAM SUPPLIED BY BALDOR ELECTRIC  
 3PH DV, 9 LEADS



**NOTES:**

1. INTERCHANGE ANY TWO LINE LEADS TO REVERSE ROTATION.
2. OPTIONAL THERMOSTATS ARE PROVIDED ONLY WHEN SPECIFIED.
3. ACTUAL NUMBER OF INTERNAL PARALLEL CIRCUITS MAY BE A MULTIPLE OF THOSE SHOWN ABOVE.

**START-UP**

1. Before initial use, review all installation instructions, check all bolts on unit making sure they are tight, and check all inlet and outlet connections, making sure they are airtight. Check connections at bottom of collector and collector drum. If an optional bin or hopper was provided, make sure the hopper door is firmly closed.
2. Check all wiring to motor, starters, and disconnects.
3. When first starting unit, listen for any unusual or excessive noise from motor or fan, and watch for any unusual vibration. If any of these occur, stop unit immediately and refer to Troubleshooting section.
4. Check all collector inlet points for adequate airflow.

**OPERATION & MAINTENANCE**

1. Make sure tube between collector and collection drum is secure. If an optional bin has been provided, make sure door is closed and tight. If an after filter is installed, make sure all cloth collection bags are in place and secure.
2. Depending on type of material collected, experience will tell when the collection drum (or an optional hopper) must be emptied. Do not let the drum overflow, but empty it when nearly filled.
3. If optional after filter is provided, the following maintenance is required.
  - A. Shake filters after each days' operation to dislodge clinging material and cause it to drop to the bottom of the bag. If clinging material builds up after a period of time and is difficult to shake loose, hand brushing or vacuum cleaning may be required.
  - B. Experience will determine how often the filter bags must be emptied using the zippered opening in bottom of each bag. It is recommended that a dust mask or respirator be worn while emptying filter bags. Do not allow bags to become more than one quarter full or the performance of bags will be adversely affected.

Continued on Page 5



- C. Under normal operating conditions, filter bags may need to be replaced every two years to maintain expected performance.
4. Follow motor manufacturer's directions for maintenance of the motor. The motor manufacturer or their authorized service center should be contracted for motor service required under the manufacturer's warranty.

## TROUBLESHOOTING

1. **Motor will not start:** Check overload heaters are in the starter and if all switches are ON; check the reset button on starter.
2. **Motor starts with a whine and is not running at full speed:** Stop motor immediately. It is "single phasing" (receiving current on 2 legs only) and will burn out if not stopped. Check fuses and wires for a break in one of the lines.
3. **Motor makes a scraping or knocking noise:** Check that the motor's cooling fan is not rubbing against its' cover. Fan blade may be loose. Tighten set screws if necessary.
4. **Little or no suction:** Check rotation of fan. Check system for blockage at inlet or outlet lines. Check for air leakage around drum cover and flex (where applicable), bin door or hopper slide gate. Check after filter (if applicable) for proper installation of filters or any blockage.
5. **Excess vibration:** Check that unit is level. Check fan blade for damage. If damaged and out of balance, return to factory for repair or replacement.
6. **Motor stopped working:** Check power is on, push starter reset. If problem persists, take motor to manufacturer's nearest authorized service center.
7. **Motor running hot-starter kicking off:** Fan may be rotating backwards (a fan motor running backwards may deliver up to 50% of rated capacity and draws more amps than normal load). Make a visual check of the rotation of the fan wheel; it should be running clockwise. Check electrical connections. Are they up to applicable codes? Are the wire gauges correct? Check if starter and heater coils are correct sizes. Check for low or high line voltage (+/- 10% is acceptable for 230-460 volts) Motor hum or growling might indicate that there are loose connections in starter or line.
8. **Excessive dust through exhaust discharge:** Check drum cover and flex(where applicable), bin door or hopper slide gate for leak. A slight leak will considerably reduce the efficiency of the unit.

## DUST COLLECTOR PARTS LIST

### MODEL 207

Motor: Baldor VM3709T, 7.5 HP, 3 Phase  
Wheel: 207 Wheel  
After Filter: B-70 (4 Required) - 207A only

### MODEL 2410

Motor: Baldor VM3711T, 10HP, 3 Phase  
Wheel: 2410 Wheel  
After Filter B-100 (4 Required) - 2410A only

### MODEL 3015

Motor: Baldor VM3713T, 15HP, 3 Phase  
Wheel: 3015 Wheel  
After Filter: B-100 (8 Required) - 3015A only

## MOTOR FAILURE

The motor manufacturer is responsible for the warranty of the motor. If the motor fails on start-up, contact the factory and arrangements will be made for a replacement. If it is found that it failed due to improper installation or wiring, customer will be responsible for replacement or repair. If motor fails after initial start-up, it must be sent to a manufacturer's authorized repair center. Do not send the motor back to Car-Mon Products, Inc. without an RGA number. (Return Goods Authorization) Because the motor is covered by the motor manufacturer's warranty, Car-Mon has no responsibility for any costs involved in motor replacement. If you need the location of the nearest motor manufacturer's service center, please call Car-Mon customer service at 847-695-9000.

## MOTOR OR WHEEL REPLACEMENT ON DUST COLLECTOR

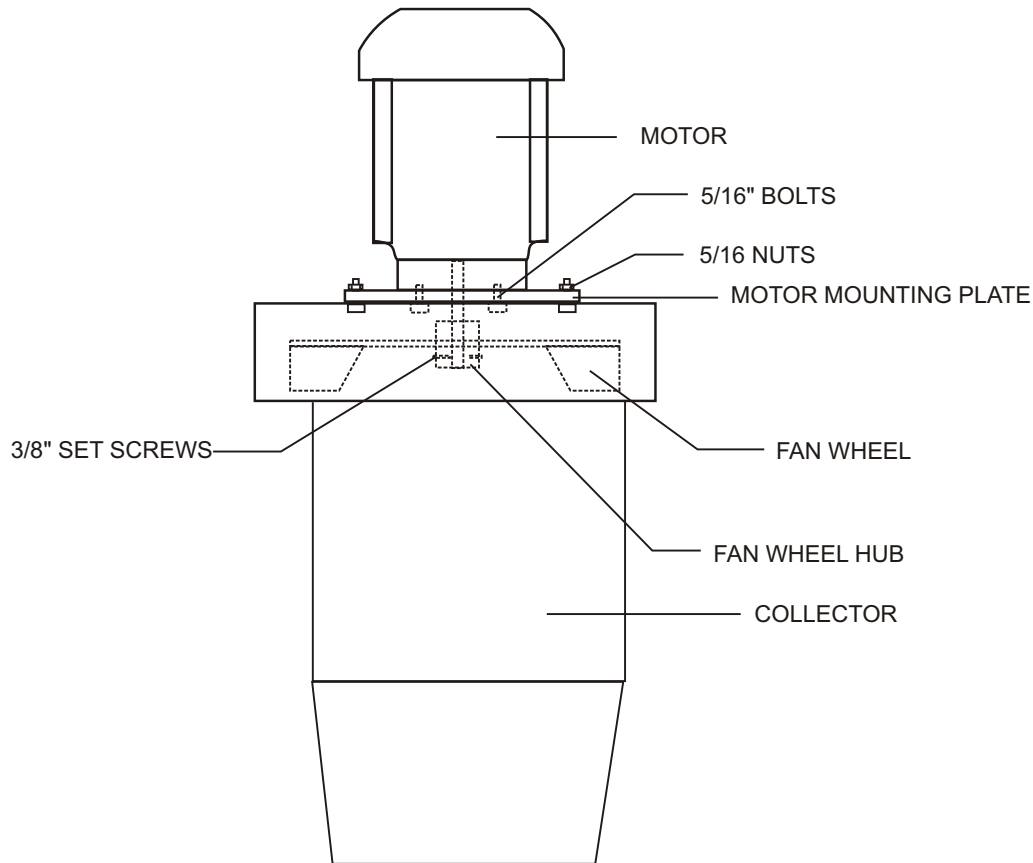

### REMOVING MOTOR OR FAN FROM DUST COLLECTOR FOR REPLACEMENT

1. Remove eight 5/16" nuts from top of motor mounting plate. The motor will have the motor mounting plate and fan wheel attached.
2. Remove fan wheel. Loosen the two 3/8" set screws on the fan wheel hub and slide the fan wheel off the shaft.
3. Separate motor mounting plate from motor by removing four 1/2" bolts.
4. Reverse procedure when installing new motor or new wheel.

#### LIMITED WARRANTY

Car-Mon Products, Inc. shall replace or repair, at its discretion, any products or components sold or manufactured which prove to be defective in workmanship or materials within one year from date of shipment.

The foregoing is in lieu of all warranties, expressed or implied, and all other obligations or liabilities on behalf of the company, regarding products it may manufacture or sell. Except as otherwise provided herein, the purchaser accepts the product "as is".

No warranty is made regarding the suitability or compatibility of any Car-Mon product for a particular application or purpose unless specifically stated. The Customer is responsible for the final selection and utilization of Car-Mon products for their use. The Customer assumes all liability for the consequences of performance, application, use and/or misuse by employees of products purchased from Car-Mon Products, Inc.

In no event shall Car-Mon Products, Inc. be liable for consequential or special damages; for transportation, labor, or other charges for adjustment, replacement, installation, incorrect electrical connections, overloading of motor, performance at low voltage, or other alterations which may be performed in connection with such products. The warranty specified herein is waived in the event that the Distributor, Contractor, or Purchaser perform any unauthorized repairs or modifications to the product.

With regard to products or components which are furnished by Car-Mon, Inc. but not manufactured by Car-Mon, Inc., the warranty obligation of Car-Mon shall be limited to and be the same as that of its supplier.